

From Requirements Change to Design Change: A Formal Path

Lian Wen & Geoff Dromey
Software Quality Institute



Overview

- What we will present is a formal systematic process for mapping changes in functional requirements to changes in the system architecture, the component designs and component interfaces.
- The method is based on the use of the Behavior Tree Representation and an extension of the Genetic Software Engineering Design Method presented at SEFM'2003

Changing Software is a Difficult Task



There is a big gap between the problem and the solution.

Hard to Keep All Documents Updated and Consistent

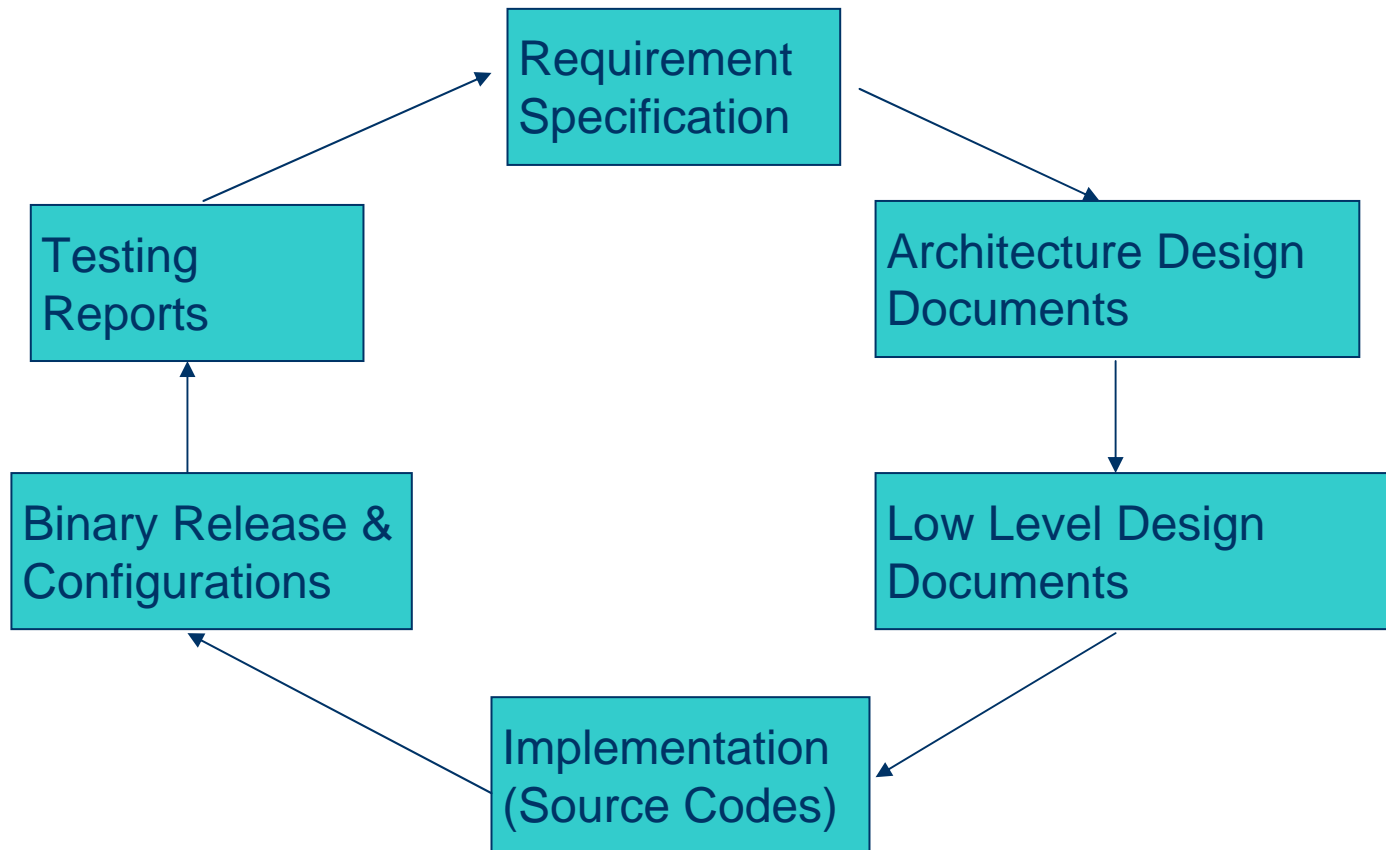

Our Solution: GSE - Bridge Between the Two domains

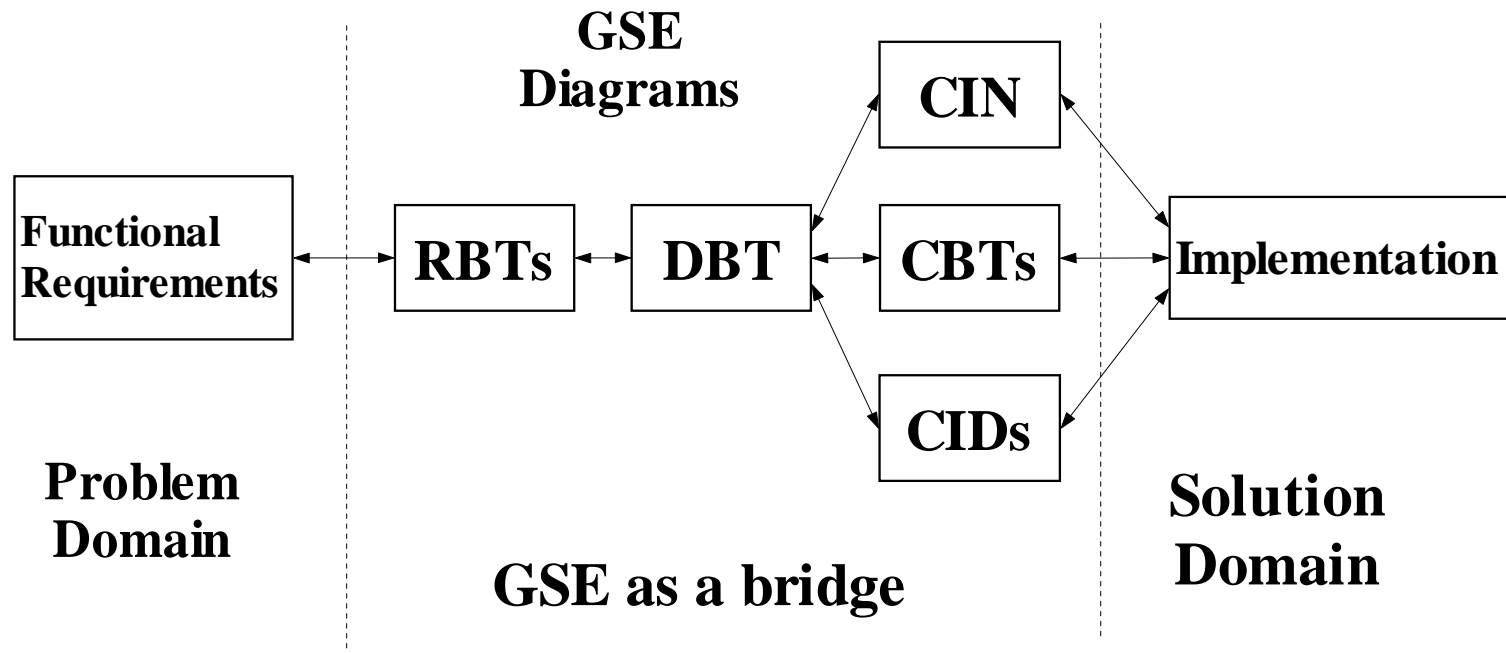

GSE (Genetic Software Engineering)

1.

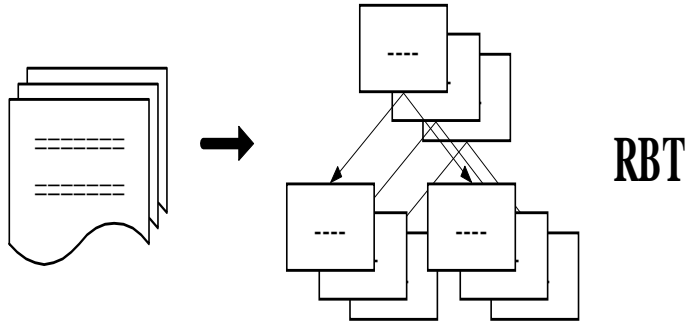

2.

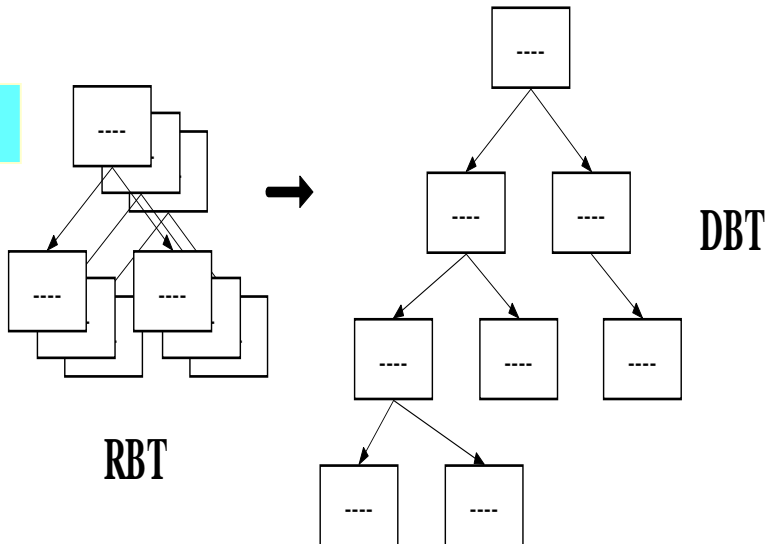

3.

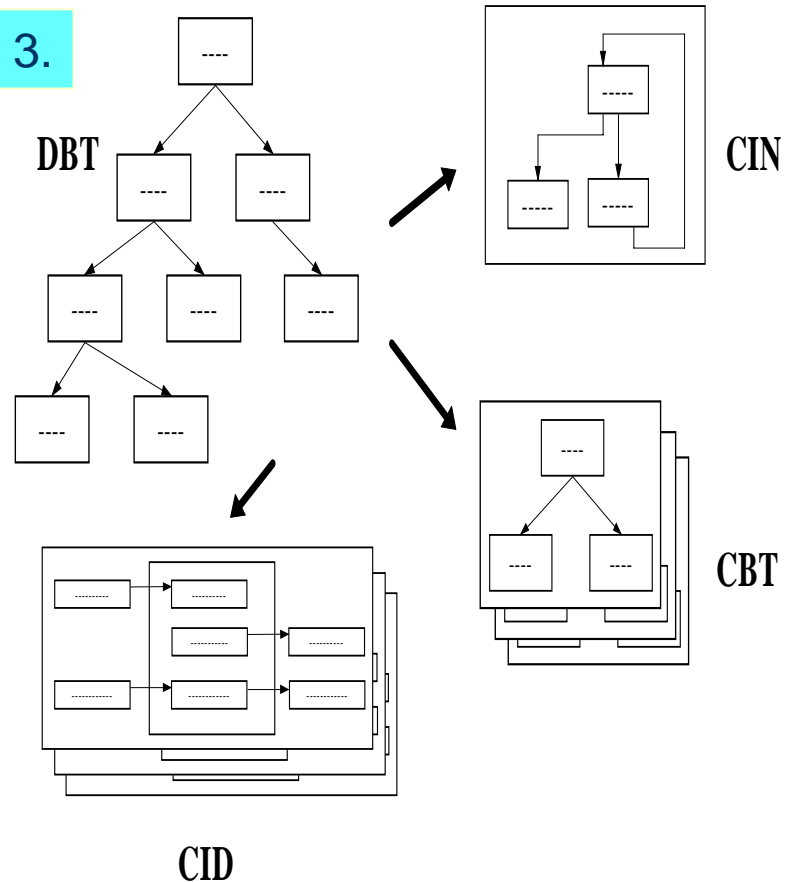

Microwave Oven Study Case

- **R1.** There is a single control button available for the user of the oven. If the oven is idle with the door is closed and you push the button, the oven will start cooking (that is, energize the power-tube for one minute).
- **R2.** If the button is pushed while the oven is cooking it will cause the oven to cook for an extra minute.
- **R3.** Pushing the button when the door is open has no effect (because it is disabled).
- **R4.** Whenever the oven is cooking or the door is open the light in the oven will be on.
- **R5.** Opening the door stops the cooking.
- **R6.** Closing the door turns off the light. This is the normal idle state, prior to cooking when the user has placed food in the oven.
- **R7.** If the oven times-out the light and the power-tube are turned off and then a beeper emits a sound to indicate that the cooking is finished.

Translate Requirements To Requirement Behavior Trees

Requirement-7

If the oven times-out the light and the power-tube are turned off and a beeper emits a sound to indicate that cooking has finished.

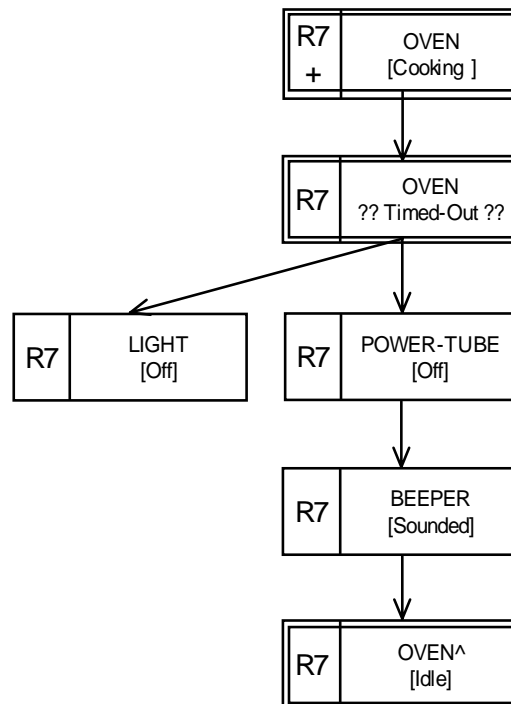

More Examples

Requirement-3

Pushing the button when the door is open has no effect (because the button is disabled)

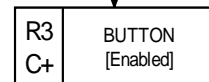
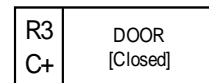
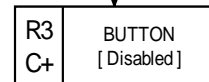

Requirement-6

Closing the door turns off the light. This is the normal idle state prior to cooking when the user has placed the food in the oven.

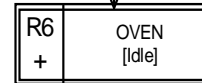
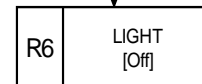
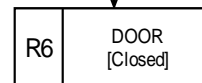
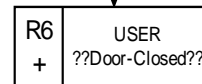
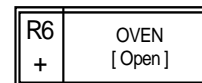

Integrate Behavior Trees

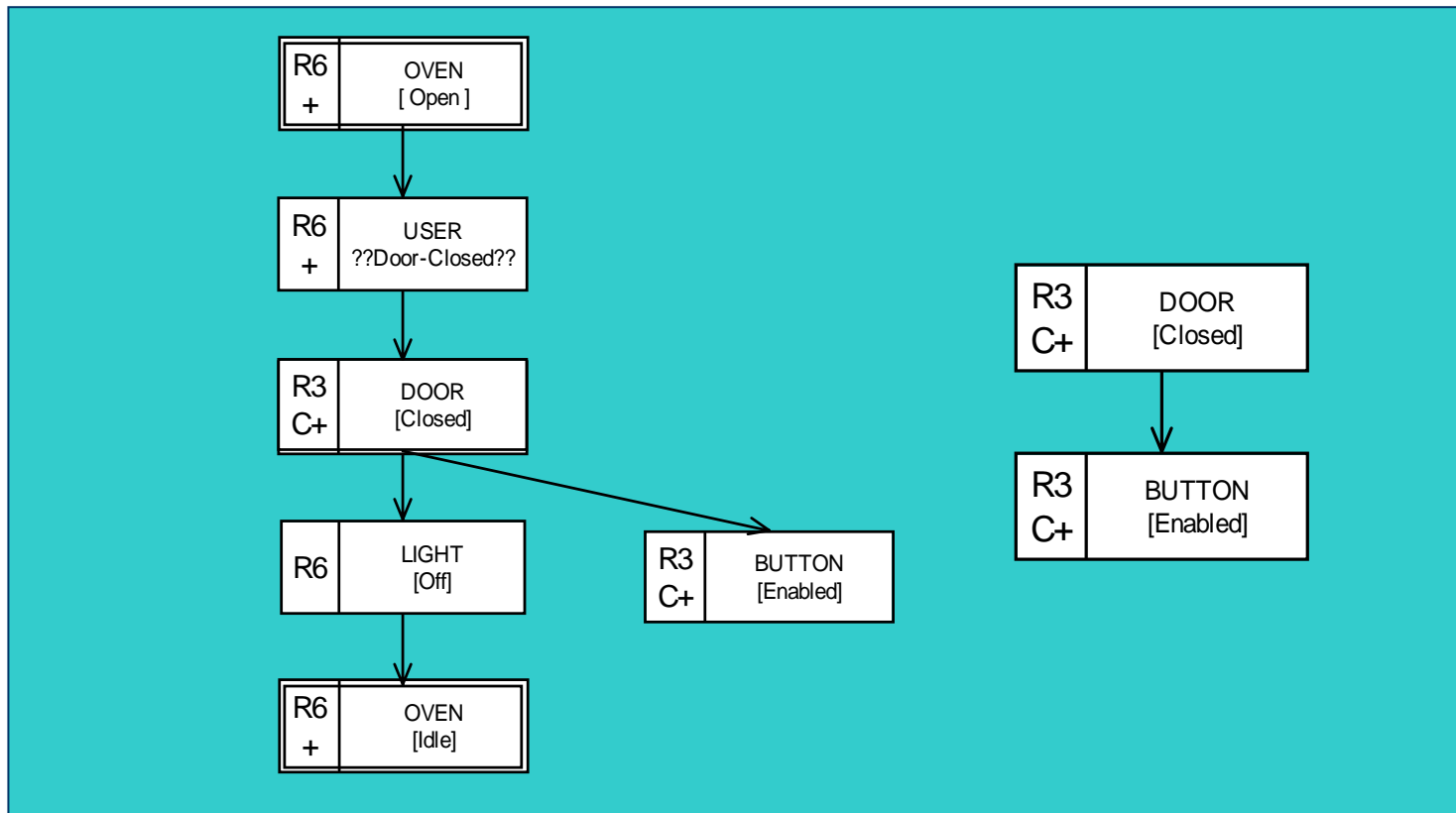

DBT (Design Behavior Tree)

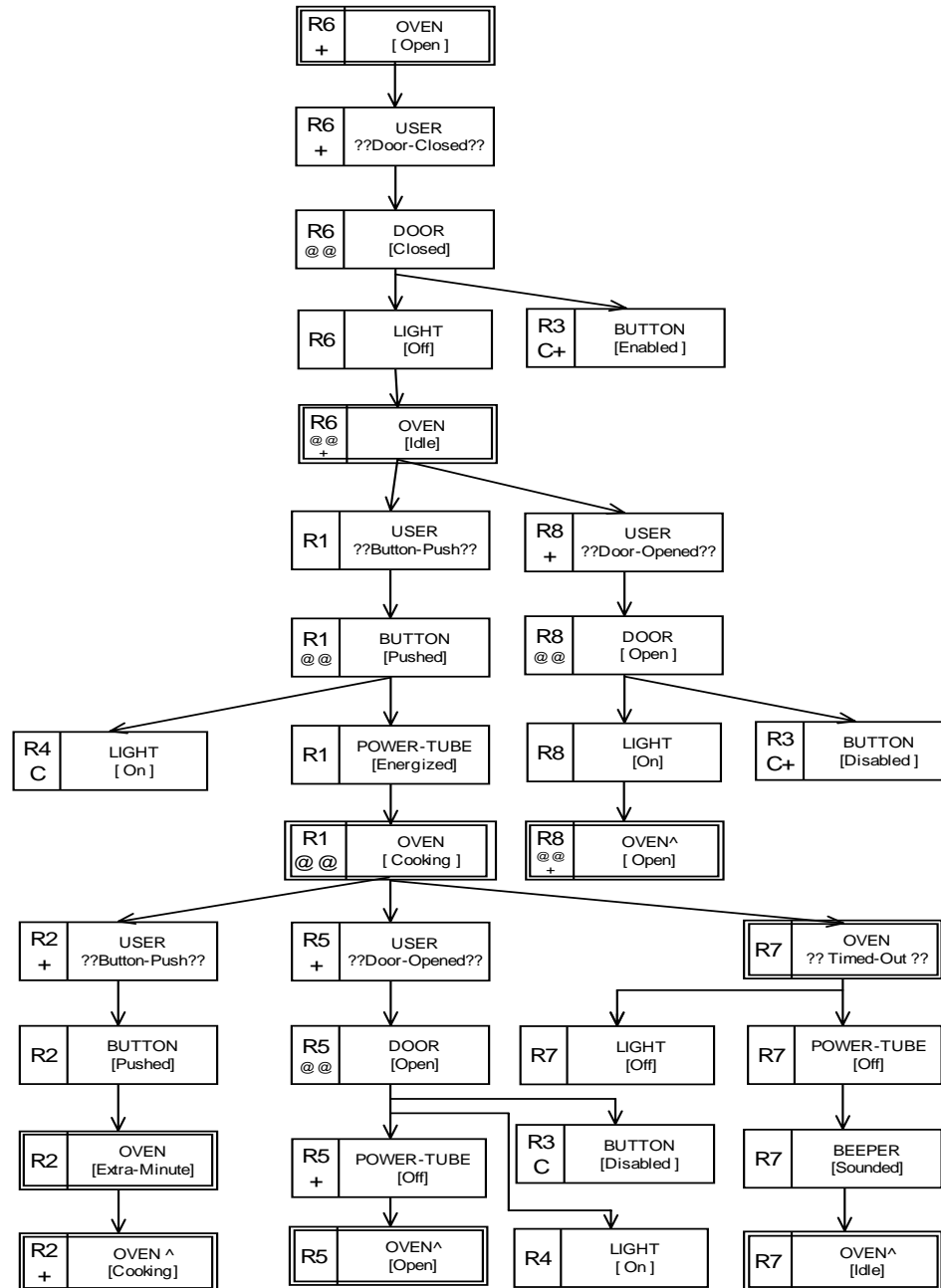

From DBT to Component Interaction Network (CIN)

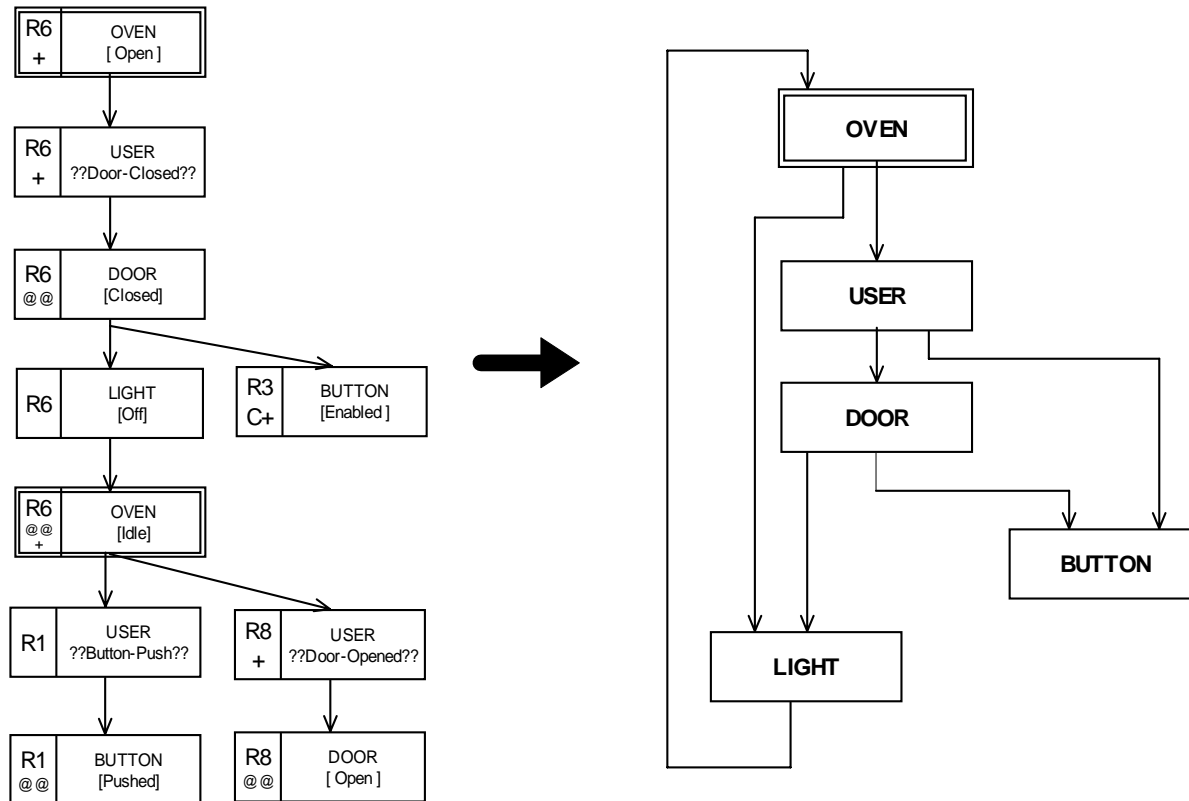

The Completed CIN

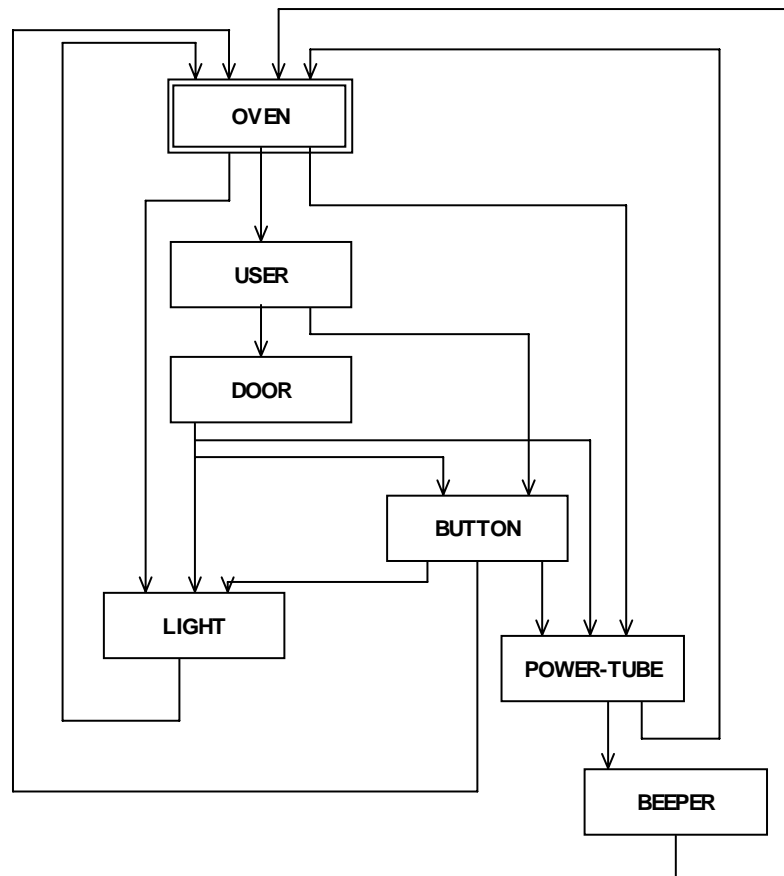

From DBT to CBT

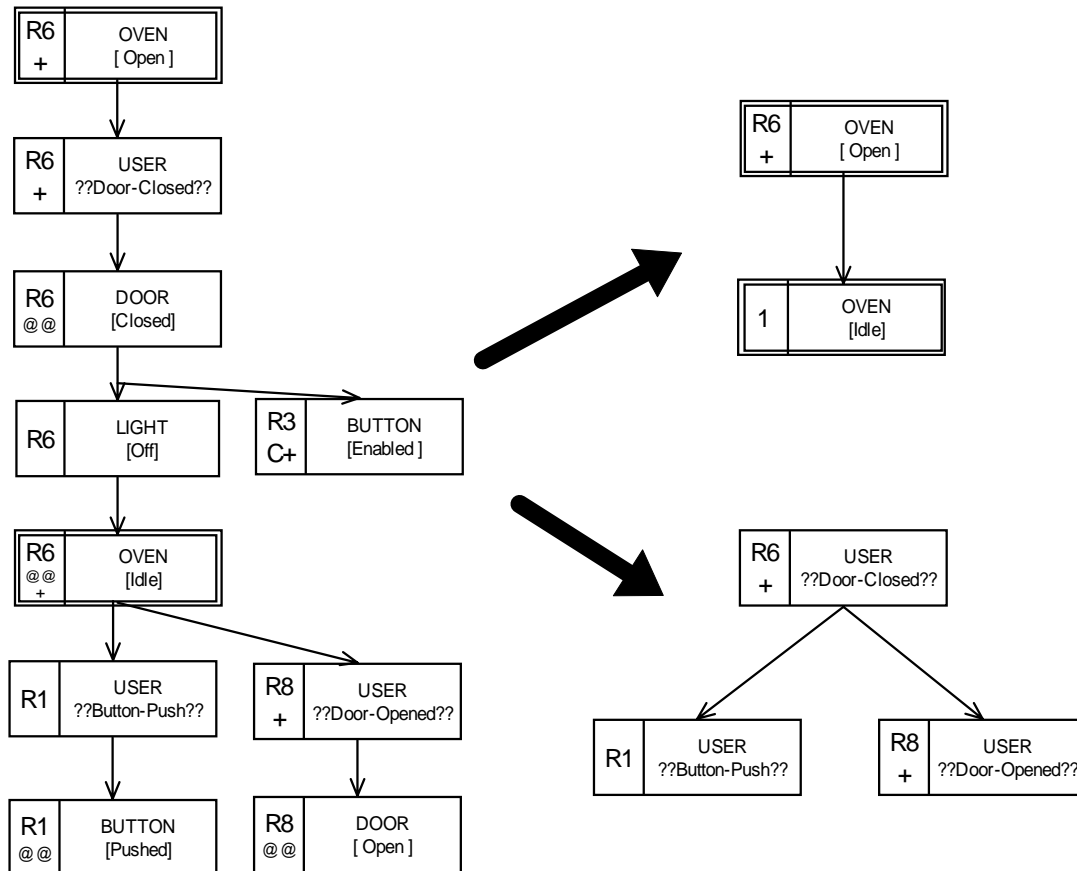

The Completed CBT of OVEN

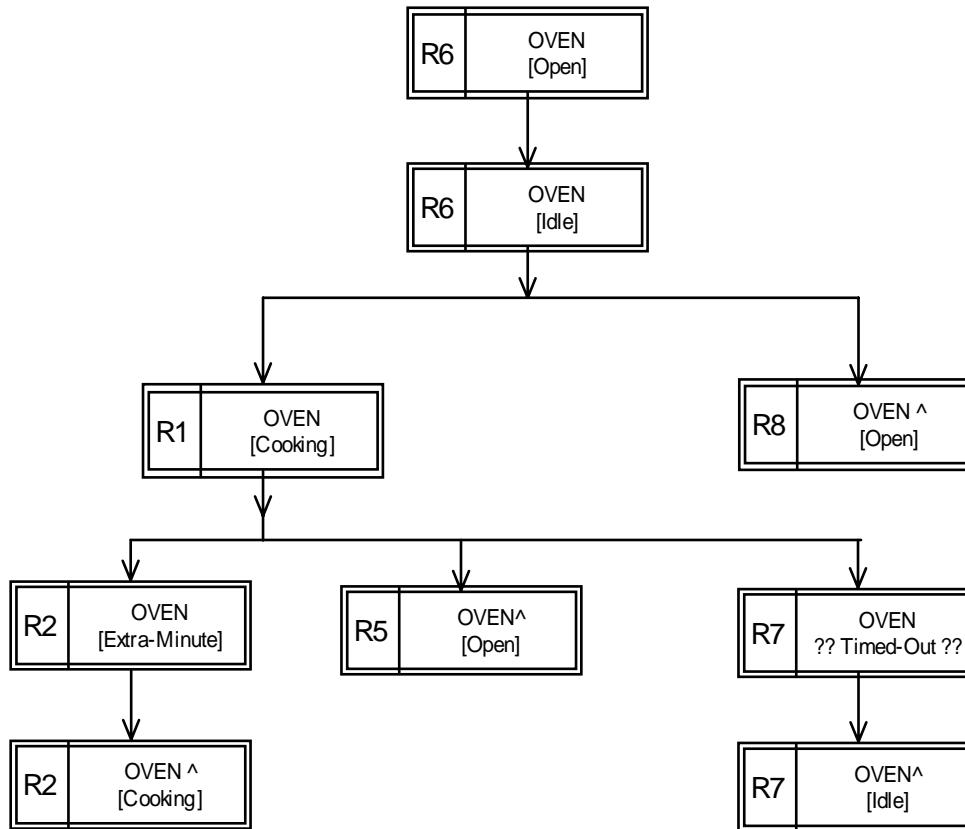

From DBT to CID

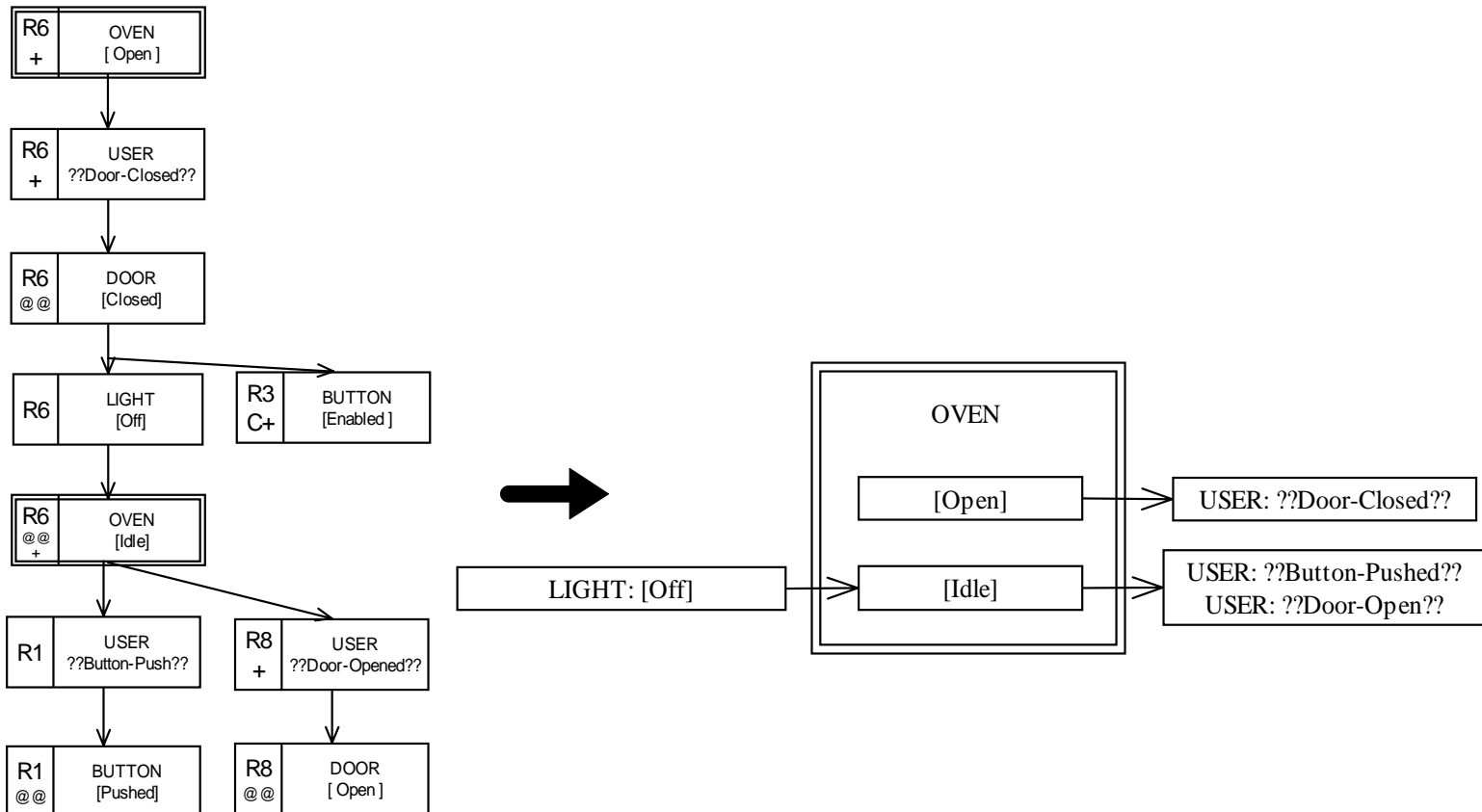

The Completed CID of OVEN

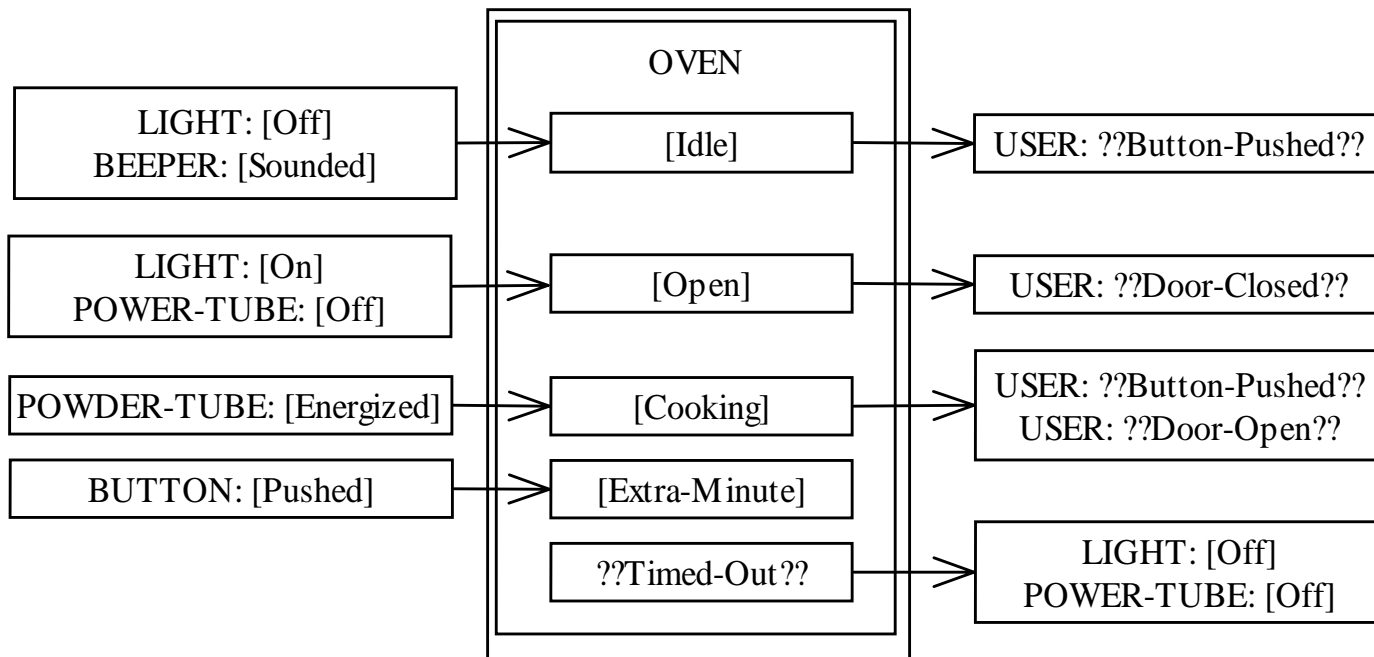

Our Traceability Model

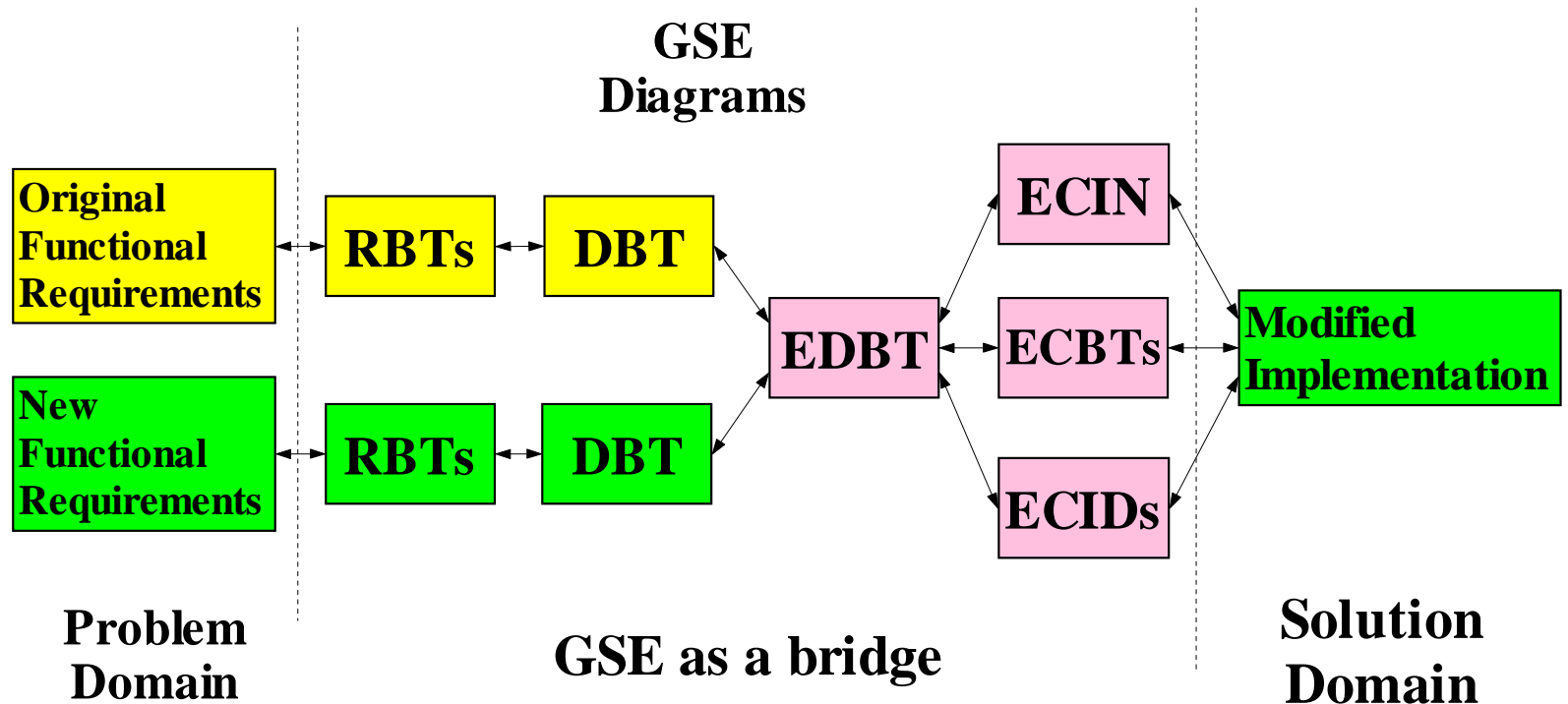

Editing Design Behavior Tree (EDBT)

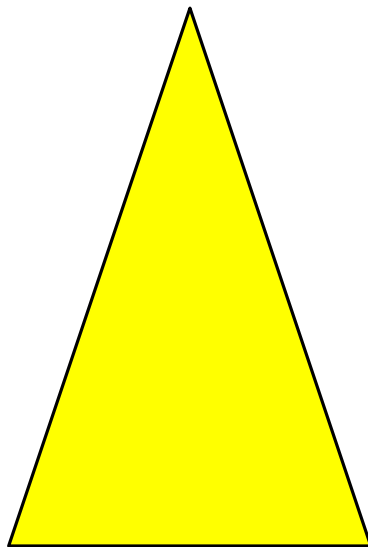

Old DBT

+

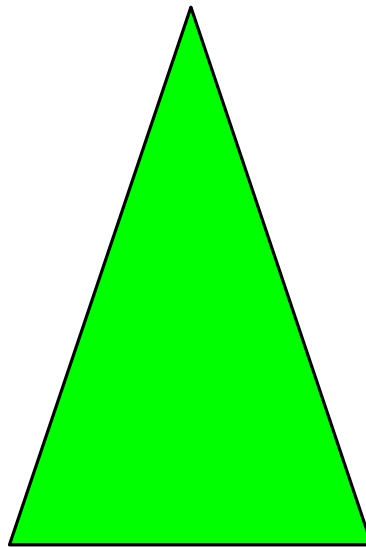

New DBT

=

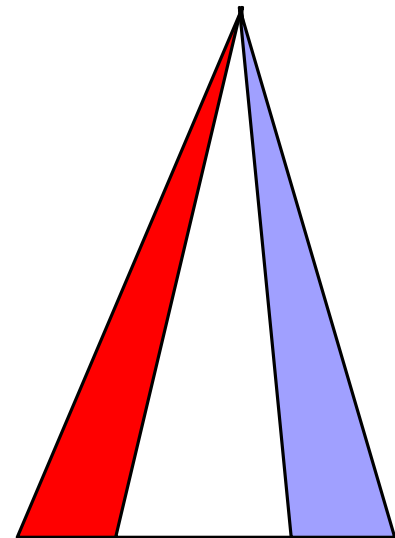

Editing DBT

Editing Information

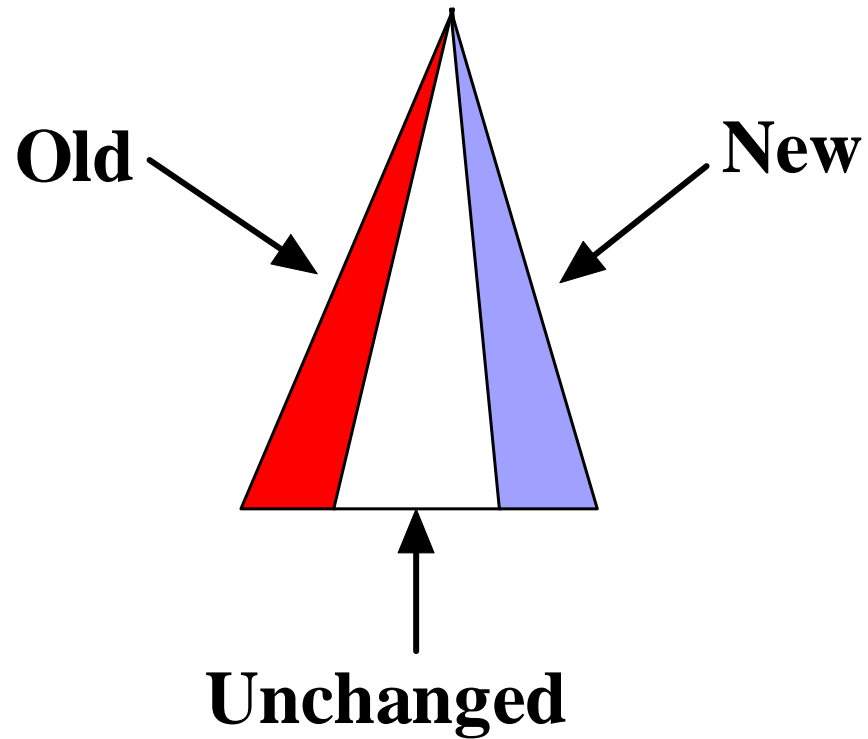

Merging of Behavior Trees

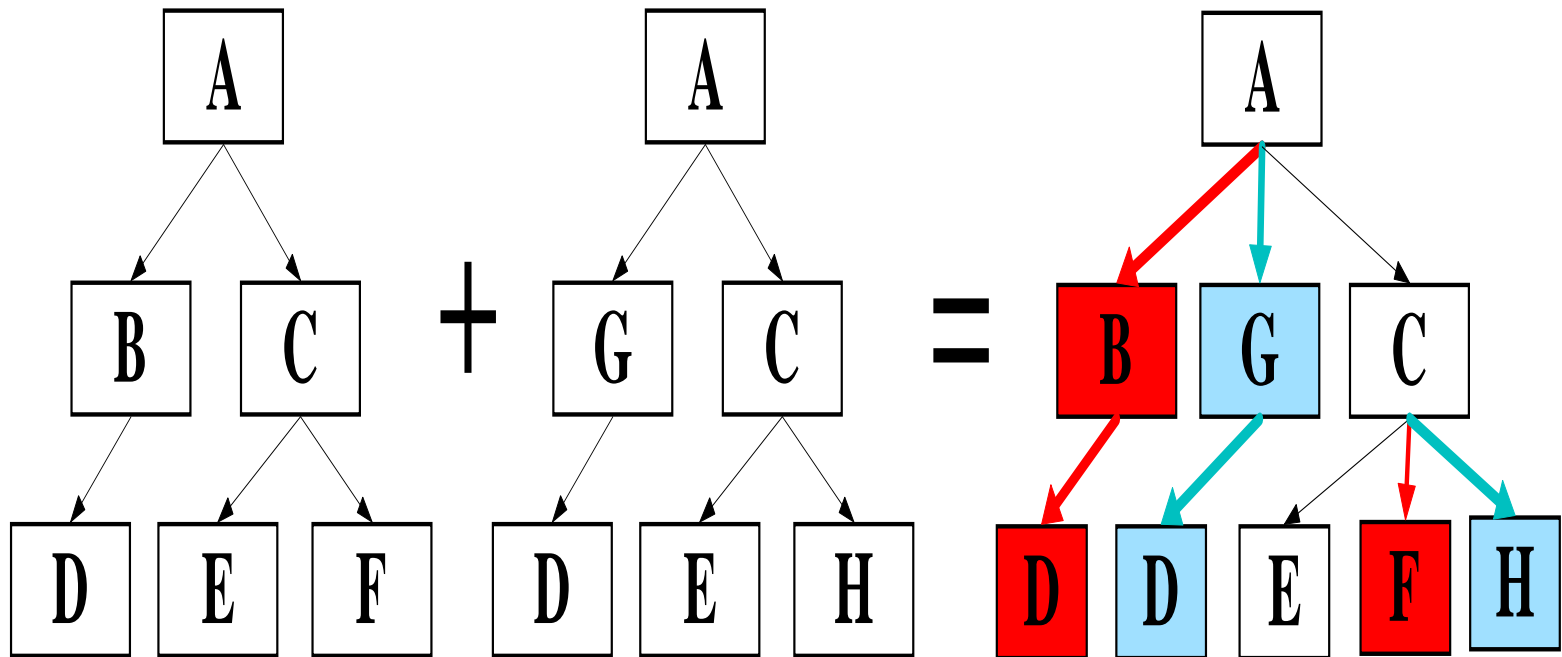

Editing Projection Rules

- “New” to “new”.
- “Old” to “old”.
- “Unchanged” to “unchanged”.
- “New” merged with “new” equals “new”.
- “Old” merged with “old” equals “old”.
- “New” merged with “old” equals “unchanged”.
- “New” or “old” or “unchanged” merged with “unchanged” equals “unchanged”.

Example

- **Modified requirement 1:** There is a single control button available for the user of the oven. If the oven is idle state and you push the button, the timer will be set to one minute and the oven will cook (that is, energize the power-tube)
- **Modified requirement 2:** If the button is pushed while the oven is cooking it will cause the timer to add one extra minute
- **Modified requirement 7:** If the timer times-out, the light and power-tube are turned off and then a beeper emits a sound to indicate that the cooking is finished.

RBT of the modified Requirement 7

Modified Requirement-7

If the timer times-out the light and the power-tube are turned off and a beeper emits a sound to indicate that cooking has finished.

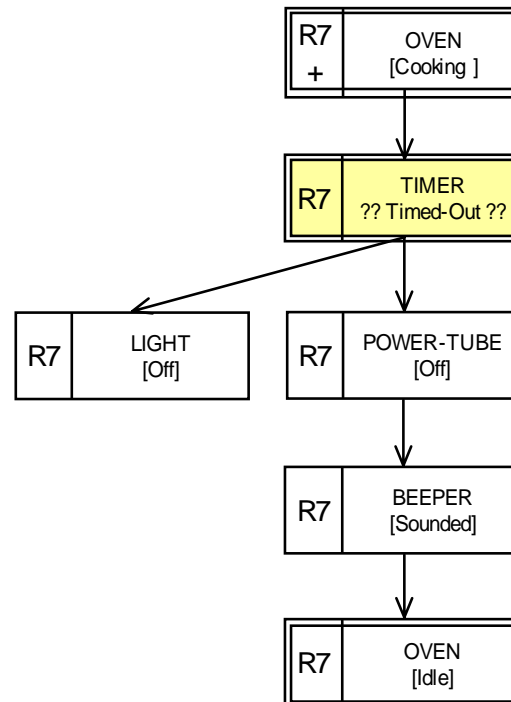

The EDBT

The EBT of Microwave OVEN.
 The removed parts are shown in light grey color, the new parts are shown in thicker lines and are filled with dark gray.

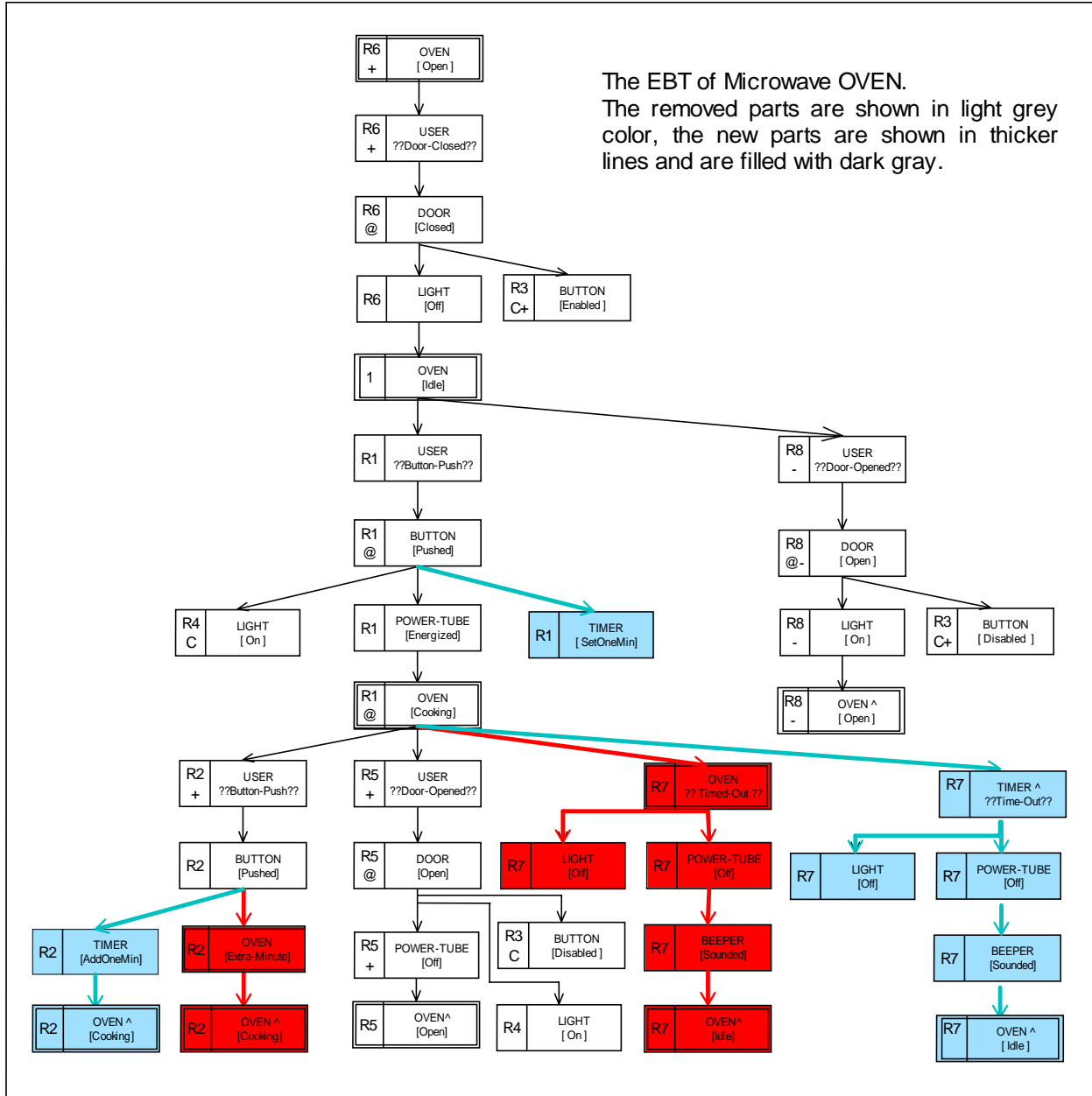

The ECIN

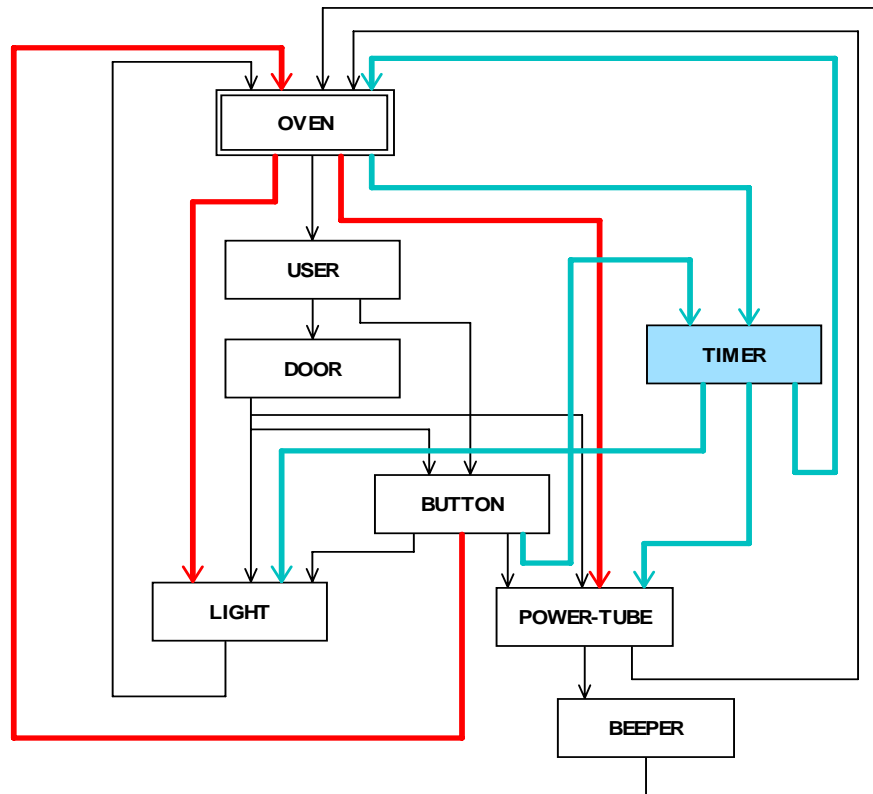

The ECBT of Component OVEN

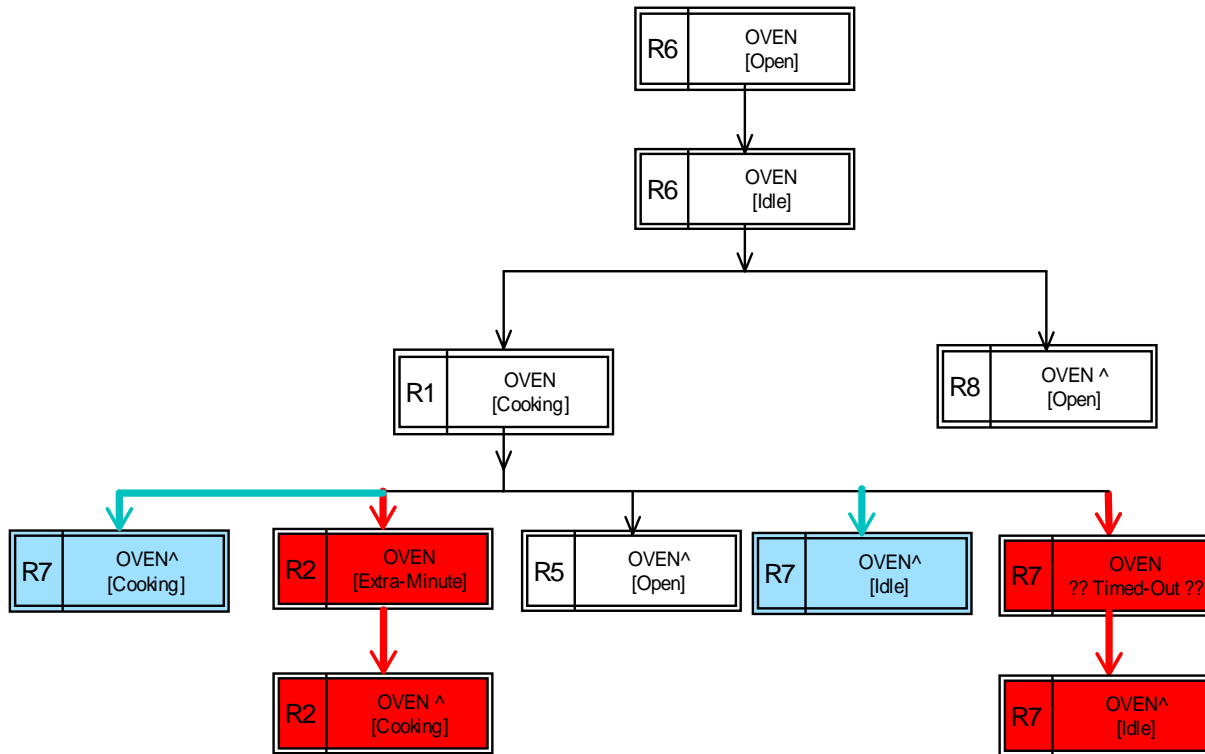

The ECID of Component OVEN

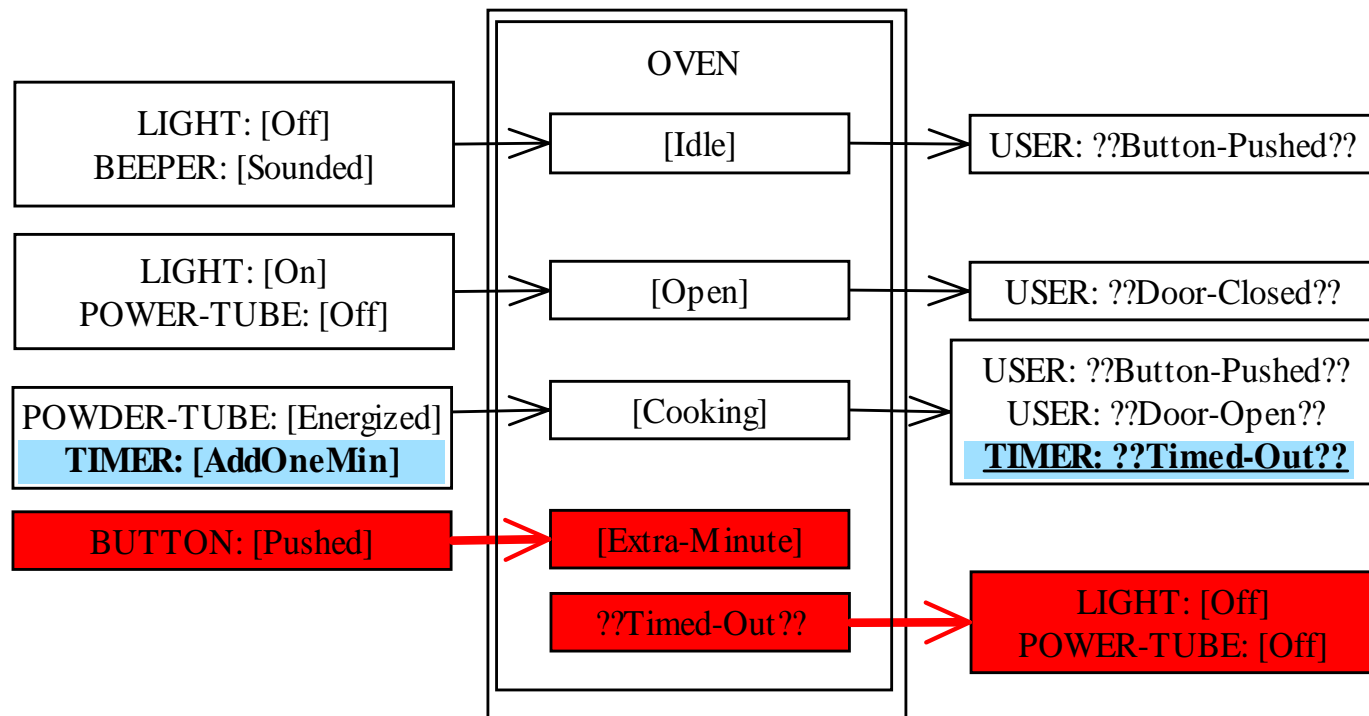

The proposed traceability model

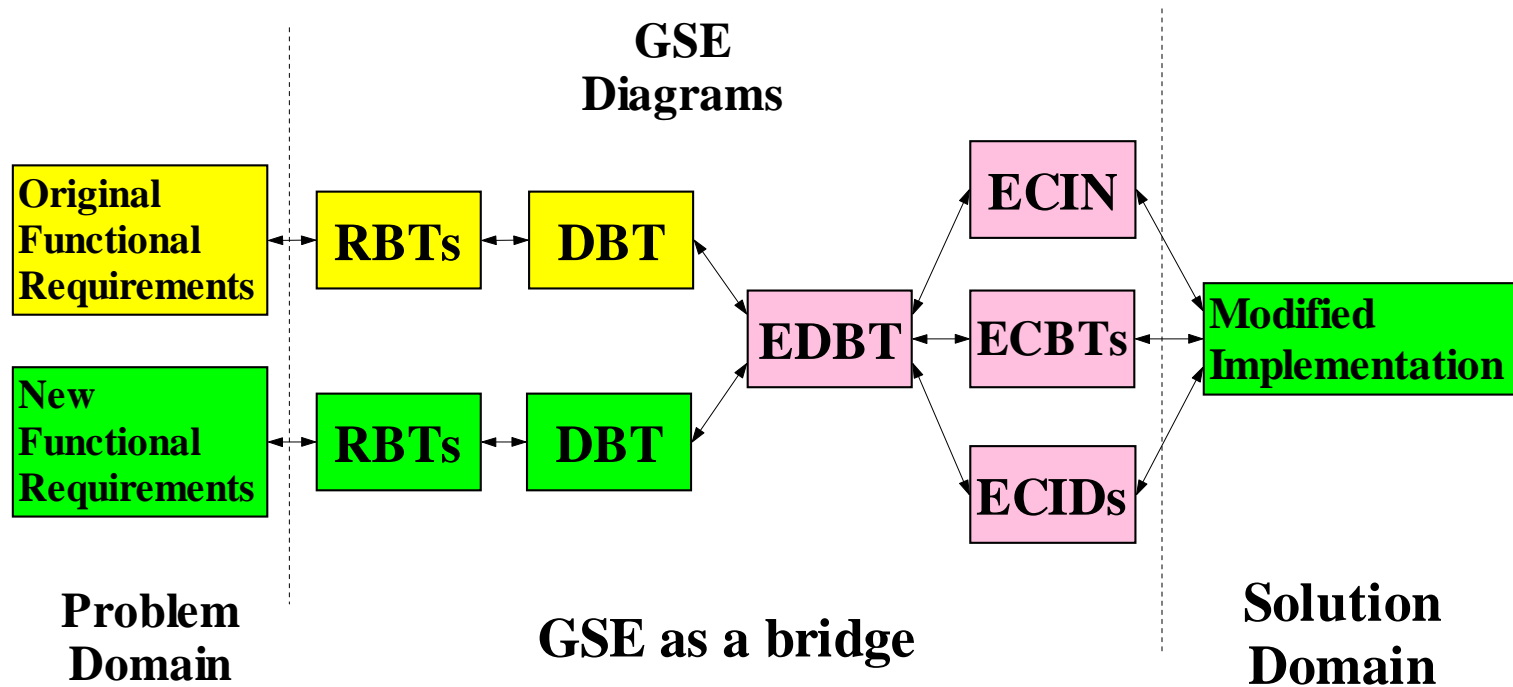

Summary

- GSE Provides
 - A formal notation for individual requirements.
 - Integrated representation of requirements - DBT.
 - Projection rules for component design, etc.
- The Traceability
 - Merging Algorithm
 - A clear notation for the change impact.
 - Systematic mapping of change from problem to solution domain
 - Improved projection rules

The End

Thank You