

CAR SYSTEM

Case Study

Geoff Dromey
Software Quality Institute
GRIFFITH UNIVERSITY



PROBLEM STATEMENT

It is required to do an analysis and high-level design for part of the functional requirements for a computerised Car System with an automatic gear-shift. The following details apply:

The car can only be started if it is in the park state when the driver inserts the key in the ignition and turns it. A dashboard light remains on if the driver's seatbelt is not fastened when the driver is seated and the ignition is on. If the handbrake is on when the ignition is on, the brake-light turns on. The security alarm is on when the car is locked, and if anyone tries to break in by breaking a window or forcing a door the alarm will sound. When the driver, on approaching the car, presses the key-button it unlocks the door and turns the security alarm off. When the door is unlocked the driver may get into the car and put it into the park state.

Model the whole process from the driver pressing the key-button, to the driver seated, to having started the engine.

SENTENCE-01 -- FR1

The car can only be started if it is in the PARK state when the driver inserts the key in the ignition and turns it.

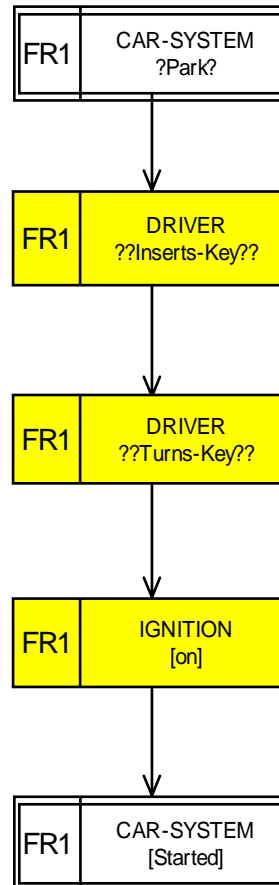

SENTENCE-02 -- FR2

A dashboard light remains on if the driver's seatbelt is not fastened when the driver's seat is occupied and the ignition is on.

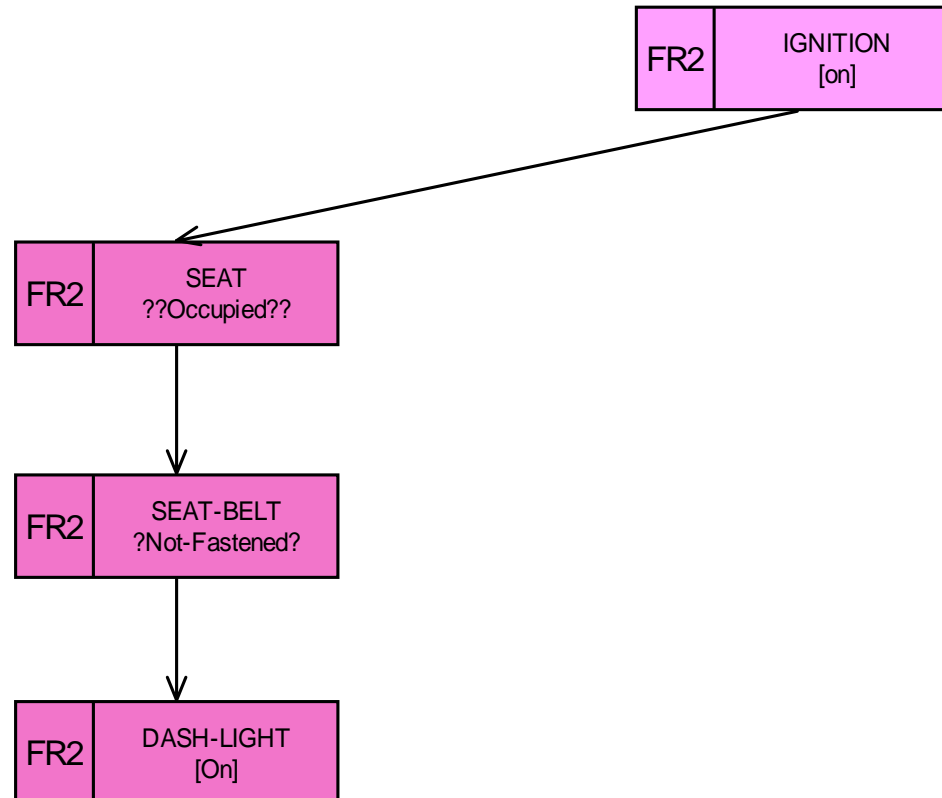

SENTENCE-03 -- FR3

If the handbrake is on when the ignition is on, the brake-light turns on.

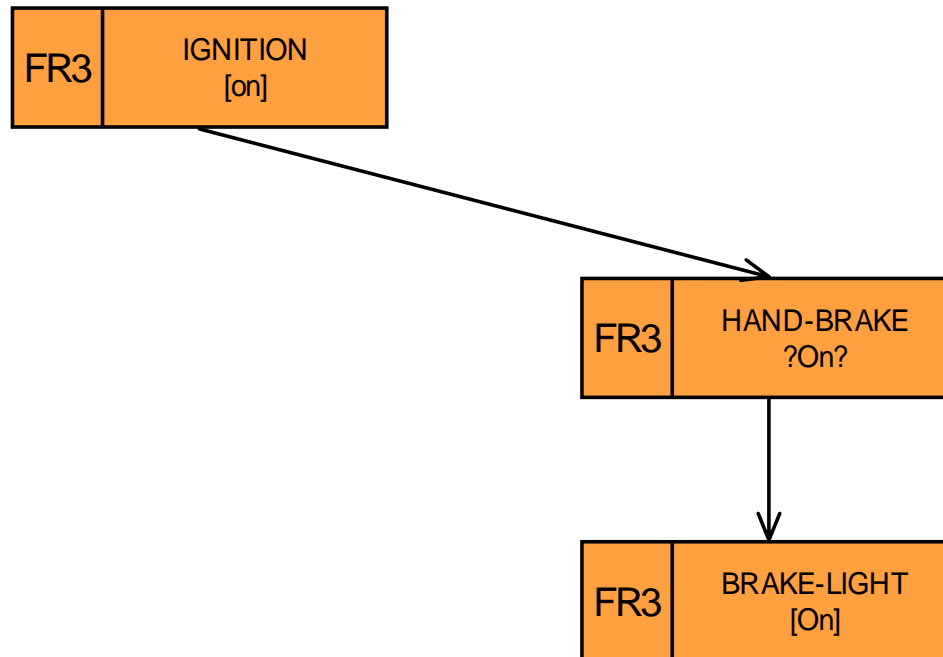

SENTENCE-04 -- FR4

The security alarm is on when the car is locked, and if anyone tries to break in by breaking a window or forcing a door the alarm will sound.

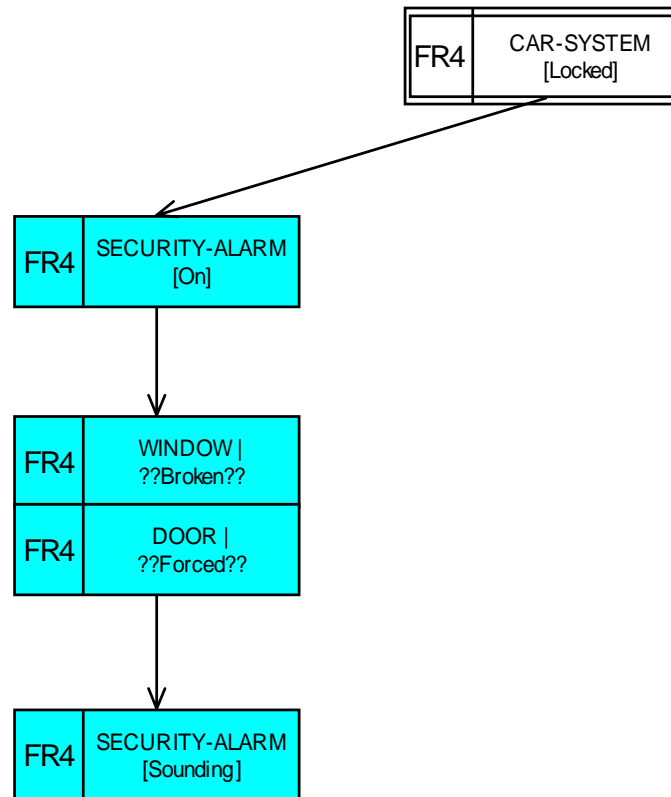

SENTENCE-05 -- FR5

When the driver, on approaching the car, presses the key-button it unlocks the door and turns the security alarm off.

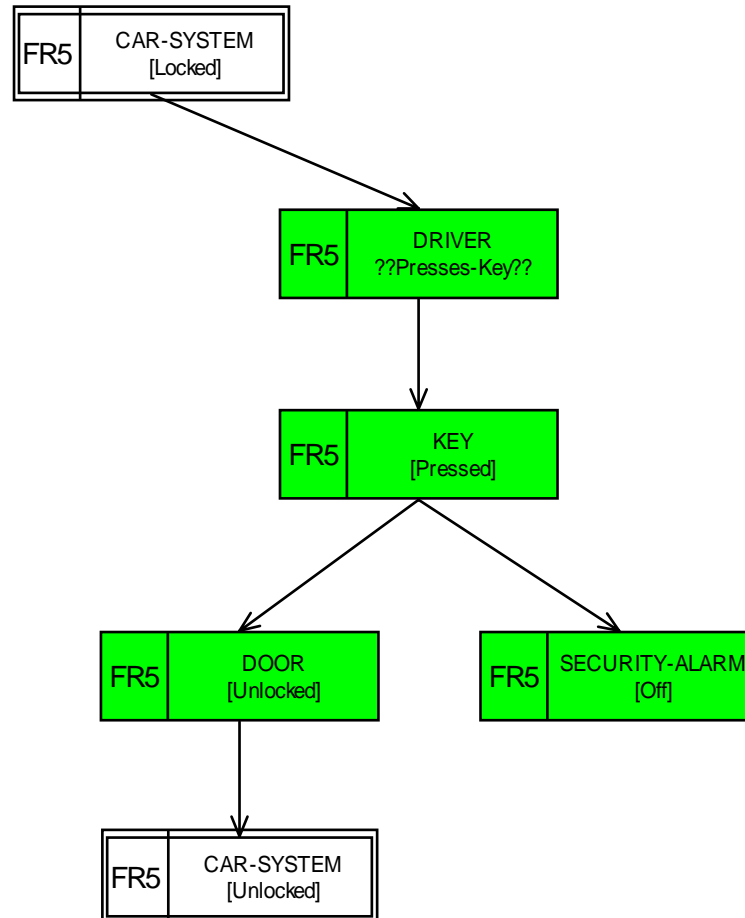

SENTENCE-06 -- FR6

When the car is unlocked the driver may get in and put the car into the park state.

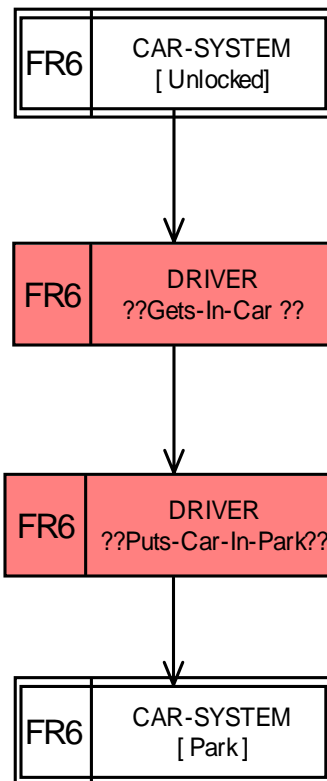

CAR-SYSTEM

Integrated Functional Requirements

